

# EXTERIOR BLINDS

Guidance – guiding channel – perpendicular

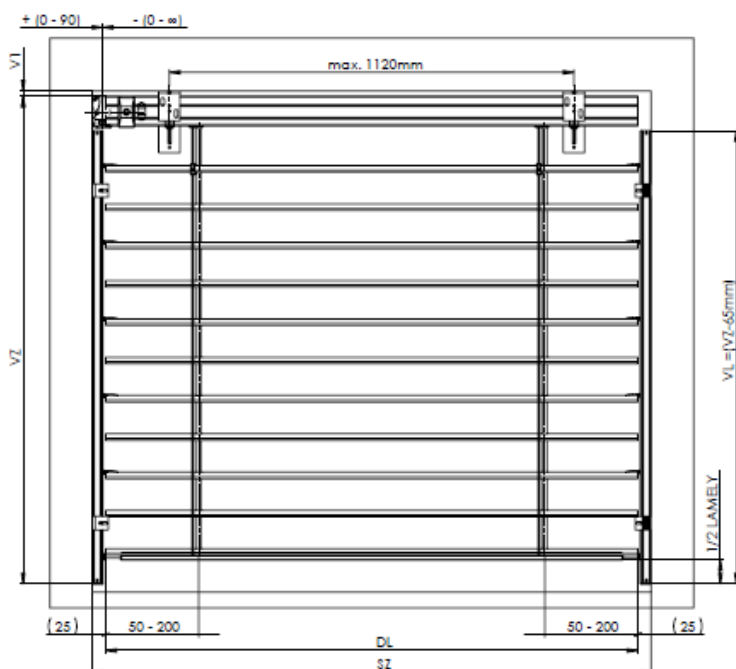

- SZ – width of the blind
- VZ – height of the blind
- DL – length of the lamella
- VL – length of the guiding bar
- VL = VZ – 65 mm
- V1 = height of the blind bracket

Guidance – guiding channel – non perpendicular

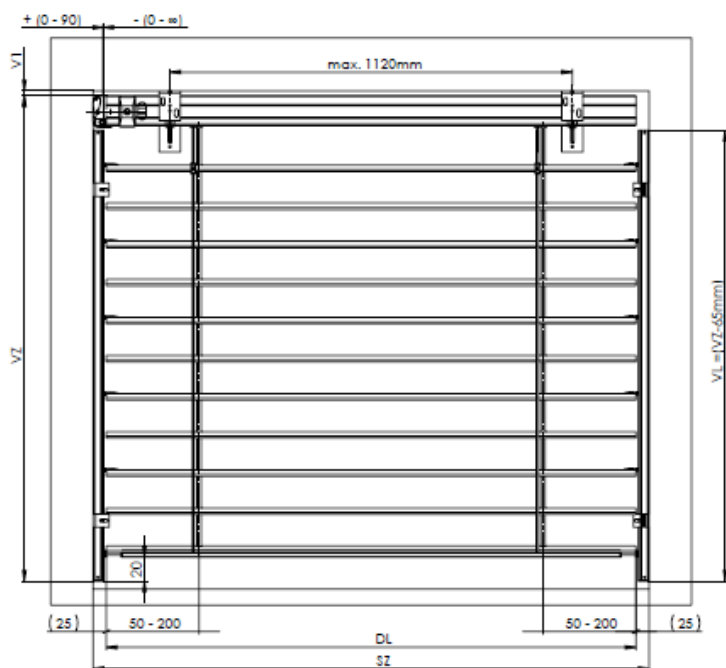

Guidance – guiding channel

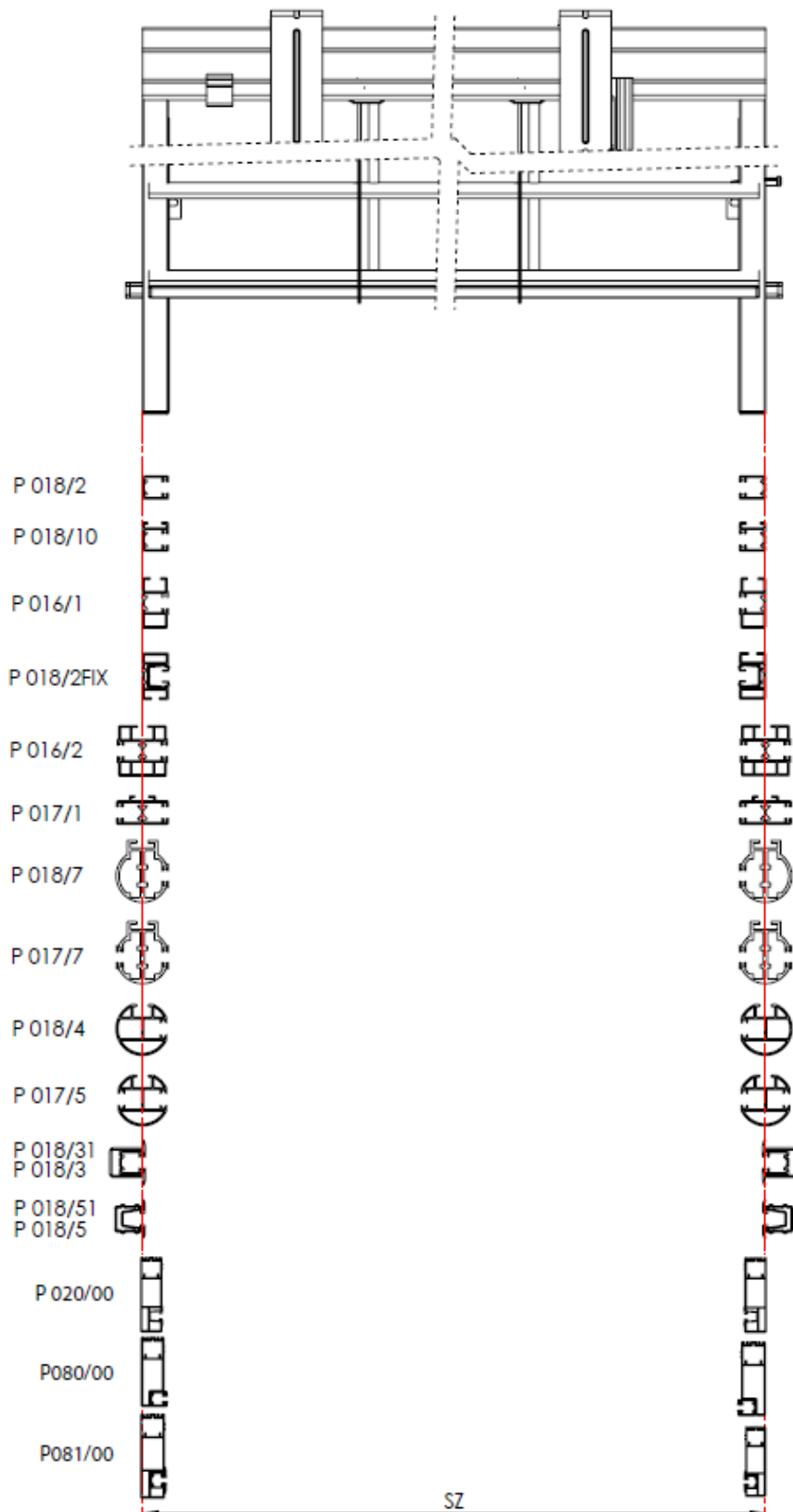

## Guidance – wire – perpendicular

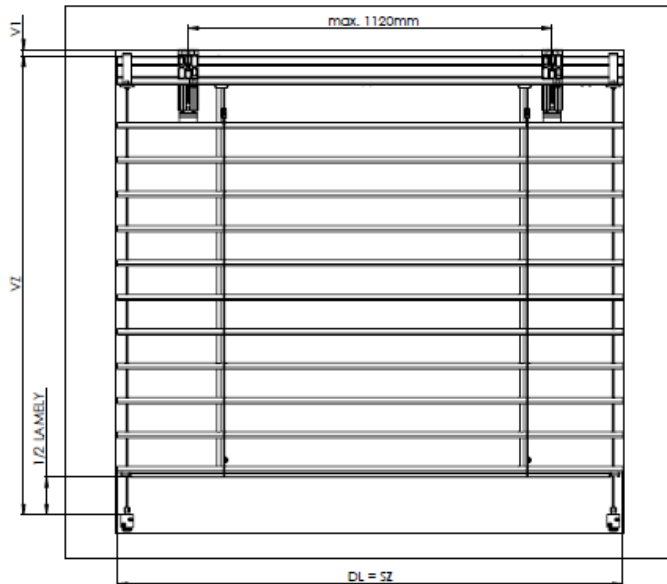

SZ – width of the blind

VZ – height of the blind

DL – length of the lamella

VL – length of the guiding bar

$VL = VZ - 65 \text{ mm}$

V1 = height of the blinds bracket

## Guidance – wire – non perpendicular

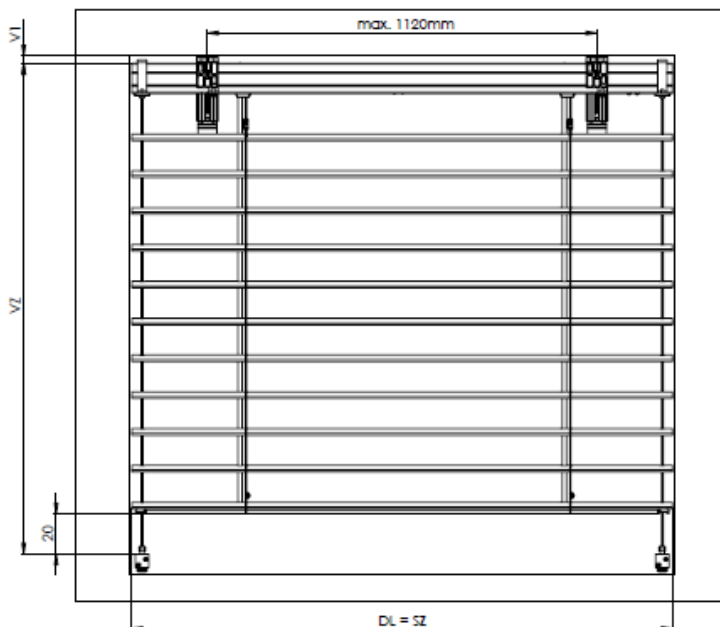

## 1. MEASUREMENT OF THE STANDARD BLIND

The height and the width are always measured in a minimum of three places. The manufacturing dimension is always the minimum measured value. Measurements are taken after the frame or window is fitted into the construction hole after completion of the outside and inside reveals, including parapets. The method of measurement of outdoor blinds is so specific that it is recommended to consult the technical issue in the construction site. Other specific solutions are possible.

In the case of control by the engine, the upper profile is shortened by 5 mm. If it is controlled by handle, the length of the profile depends on the shift of the gearbox. The position of the gearbox (possible shift) in the upper profile depends on the actual fitting of the window frame, reveal. The ladder span depends on the choice of the control (it varies within the range of 50 – 200 mm)

### **ATTENTION!**

**For sloped blinds always specify all possible sizes (width, bigger drop, smaller drop, hypotenuse length). Sloped blinds are produced only with motor control and wire guiding which needs specific tensioning (see amendment of this manual).**

## 2. ASSEMBLY

The assembly may only be performed by a qualified professional employee!

Construction preparedness for the assembly: finished reveal, colored facade, finished outside parapets.

### **INSPECTION:**

- Before assembly we recommend inspecting all the parts after the delivery of the goods to prevent any problems. The manufacturer must be notified of any defects or comments concerning the assembly or blinds.

**RECOMMENDATION:**

(It applies to Cetta blinds: C65, C80, C 80 Slim, C60F, C80F, C100F)

- In case the lower part of the blind does not fit, you can use a comb for shortening the ladders, which is included in the package. The comb is placed on the inside of the blind, on each ladder between the end slat and the last slat. This will shorten the ladder, and the slats fit better.

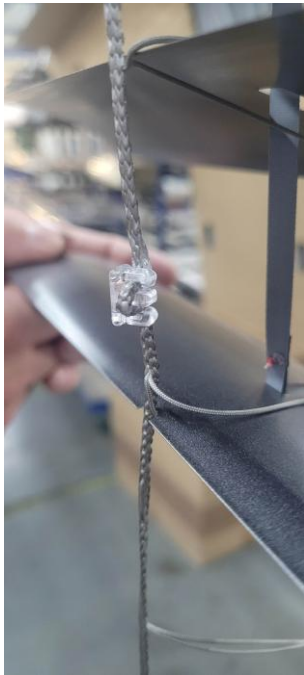

For blinds with Cetta flexi slats (60, 80, 100), fit the comb about 1/3 from the bottom of the packet.

For standard Cetta slats (65, 80), fit the comb between the end and last slats.

**ASSEMBLY TOOLS:**

1. Tape measure
2. Water gauge
3. Pencil
4. Hammer
5. Electric drill as per the source material
6. Cordless electric drill
7. Magnetic adapter
8. Bits PZ2, PH2, magnetic adapter on hexagonal head 8 and 10
9. set of Allen wrenches
10. Assembly cable
11. Small ratchet wrench and hex socket 8 mm
12. Female screw spanner No. 10 and 13
13. Set of screwdrivers, insulated, electric

**BASIC TYPES OF ASSEMBLY:****a) Cover box****ASSEMBLY PROCEDURE:**

1. Measure the hole and compare with the already prepared blind, check the control mechanism.
2. Allocate the blind holders so they do not interfere with the cloth strips (minimum distance from bearing is 100 mm).
3. Fix the holders horizontally. Always follow number of brackets recommended by the producer. It is necessary to consider the type of carrying surface and bracket positioning. The reason is the right choice of fixing in relation to carrying capacity of a facade and resonations elimination. It is advised to use isolated blind brackets. For smooth run it is recommended to mount the brackets min. 100 mm from the nearest bearing of a blind.
4. Insert the blind into the sleeves in the holders and secure. Do not tighten the sleeves.
5. Prepare the passage for control using the handle or the cord. If there is an electric control, connect the socket.

6. From the inside passage attach the handle; if the drift is long, shorten it to the necessary length. Stretch the endless cord through the created hole. Attach the cover for the passage of the cord.
7. Center the blind and tighten the screws on the sleeves in the holders.
8. Equip head rail with black guiding rail arresting brackets. On the lamella guides attach the guiding bars which are already fitted with the holders for the guiding bars, guiding rail in top part fit in black arresting bracket and attach them on the window frame or into the reveal (for assembly into the reveals, the guiding bar holders are not used and the guiding bar is attached through the holes created in the body of the guiding bar). Guiding rails have to be installed with arresting bracket on the center of head rail.
9. Lower the blind into the lower position (attach the holders for wires if the blind has wire guided lamellas). At the same time, check that the guiding bars or wires do not clamp the lamellas. Check the vertical position of the guiding bars. The blinds must not run at any angle, they are not designed for that, and the slats could run erratically.

**ATTENTION:** Check flatness – horizontal position of the blind slats while running. In case of poor movement, adjust the horizontality of the slats on the bearing eccentric – the white rotating pin that holds the textile strip. By turning the eccentric **in the lower end position** of the blind by a maximum of 90 degrees, you will affect winding of the strip, it will wind less, and therefore you will let down this side lower. **Then check the movement of the blind by running it along its entire path, and if necessary, make further adjustments.**

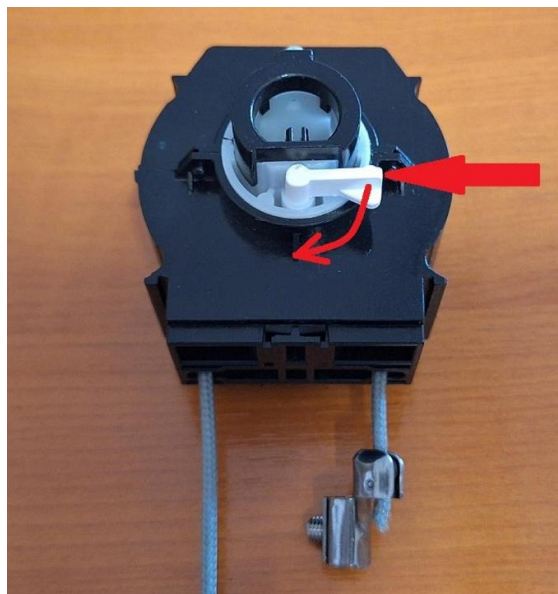

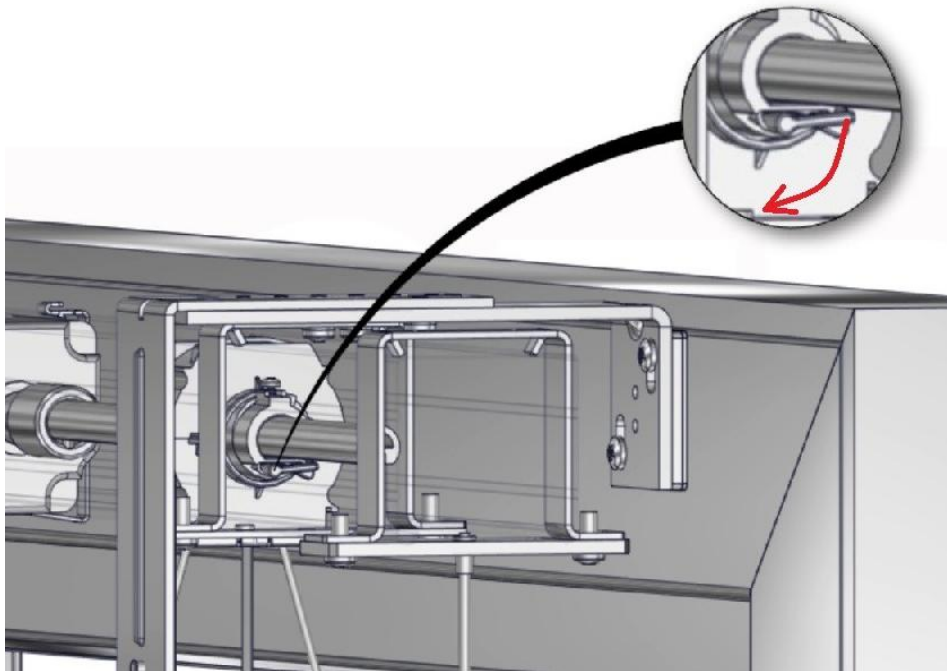

10. When the lamellas are tilted, attach the cover box to the holders, insert the prolongation of the holder (tighten the fixation screw) into the pocket created on the cover metal sheet and secure the cover sheet using the screw through the hole in the holder for the blind (Tex screw). The front covers must be tightly fixed to their holders.
11. The blind driven by the engine can be inspected using the assembly cable or adjust the end positions of the engine and the connection to the supply cable.
12. Fix the holders of the handle in the interior. Connect the control switch according to the connection diagram supplied.

In case of non-standard mounting and using non-system fixing elements, the producer does not bear any responsibility for resonations and disturbing noise.

**b) The cover box incorporated into the heat-insulation system or the peripheral shell****ASSEMBLY PROCEDURE:**

1. Mount the blind brackets into prepared space box in isolated system or building cladding. Always use recommended number of brackets. It is necessary to consider the type of carrying surface and bracket positioning. The reason is the right choice of fixing in relation to carrying capacity of facade and resonations elimination. It is advised to use isolated blind brackets. For smooth run it is recommended to mount the brackets min. 100 mm from the nearest bearing of a blind.

After building isolation or after cladding finishing the mounting of a blind progress according to the previous instruction starting from point 4.

**Note:**

For correct guiding wire tensioning follow the process below:

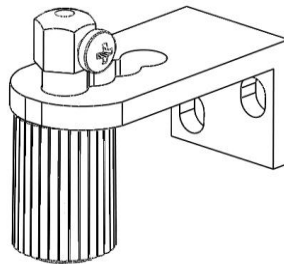

1. After choosing the correct position of wire guiding bracket and it's screwing it is necessary to release the plastic housing with female screw up to edge of the tensioning screw thread (unscrew).
2. Put the wire through the tensioning screw.
3. Push the whole tensioning mechanism upwards to the bracket body, hold the wire in slightly tensioned position and fix it with M4 screw with cross-point screwdriver.
4. Turn the plastic housing by 3-4 turns and tension the wire. Remove the waste wire below the bracket.

It is necessary to keep prestressed 2 mm tolerance between upper part of wire bracket and lower part of tensioning screw.

5. By following the above steps, you will assure correct wire guiding tension.

ILLUSTRATIVE ASSEMBLY:

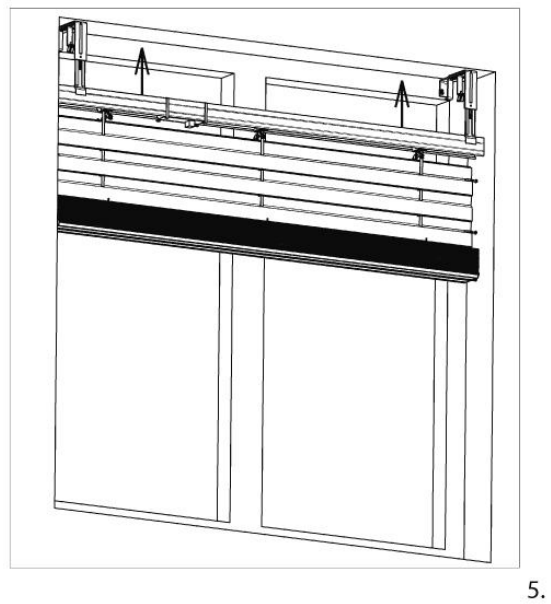
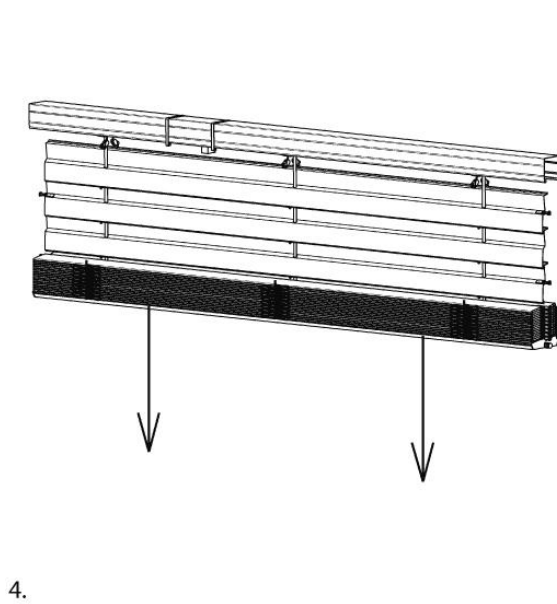
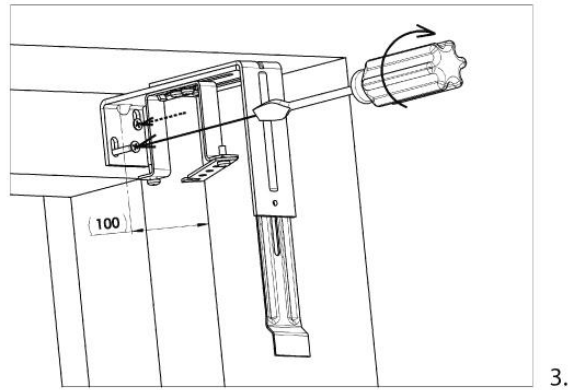
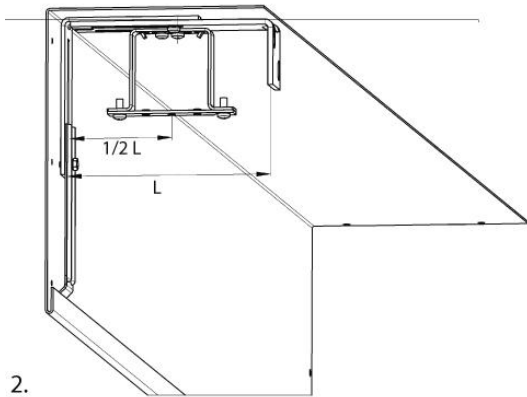
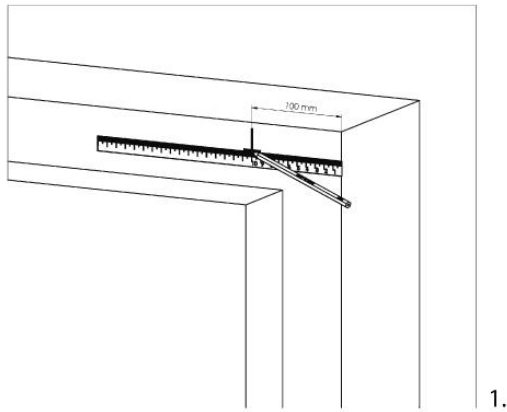

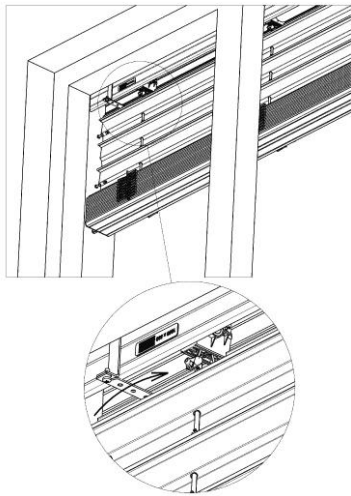

6.

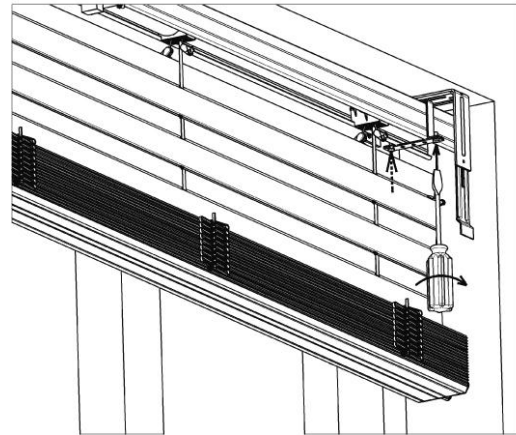

7.

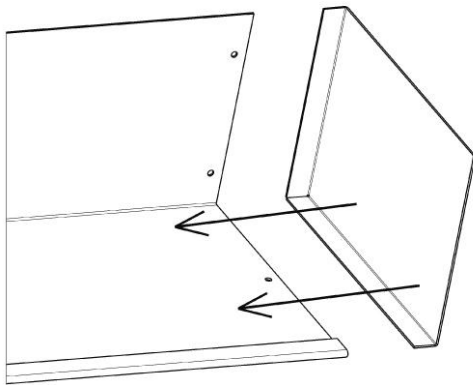

8.

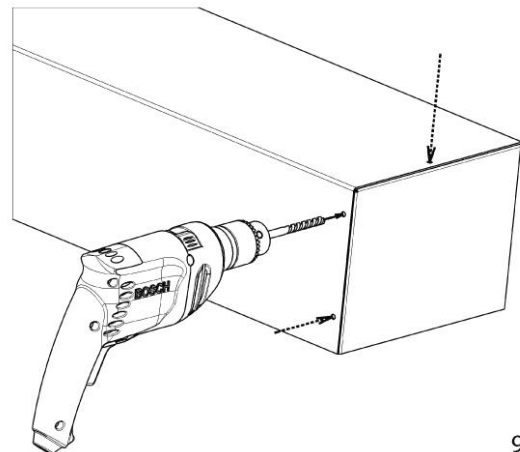

9.

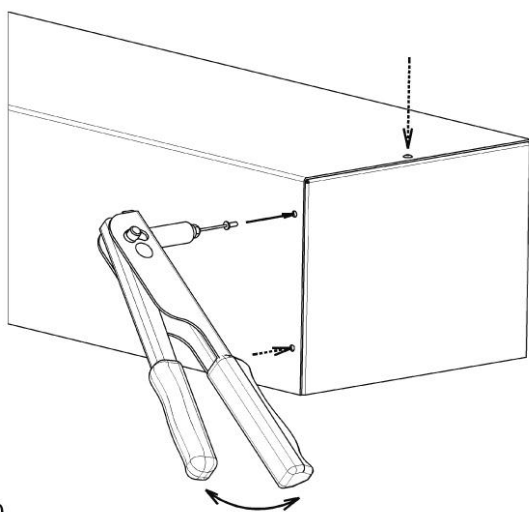

10.

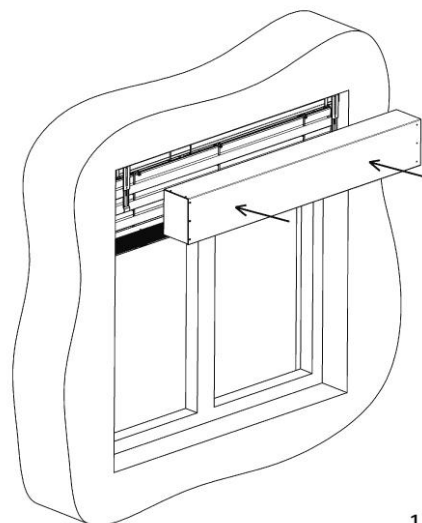

11.

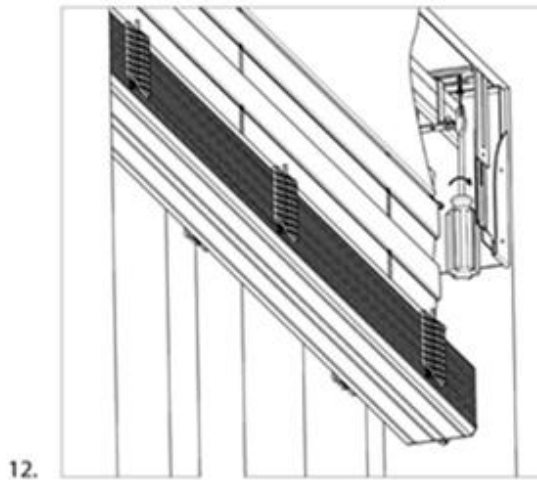

12.

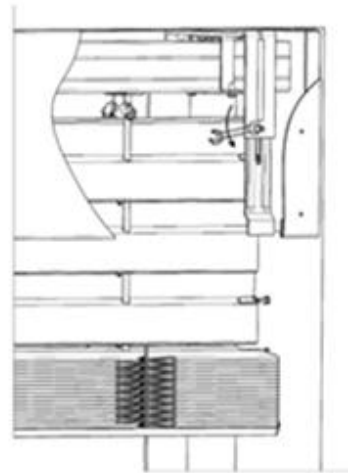

13.



14.

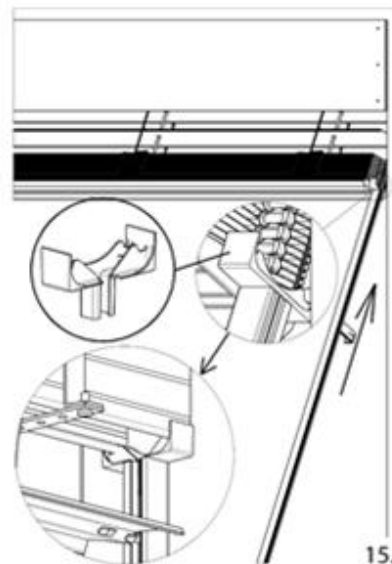

15.

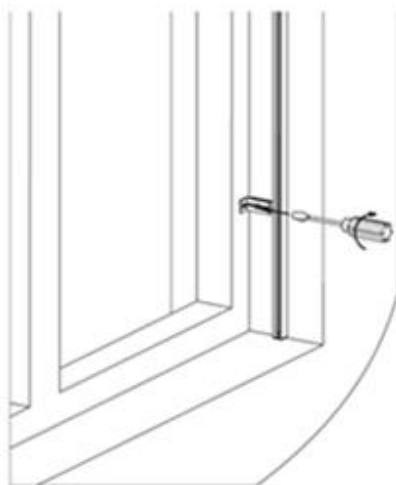

16.

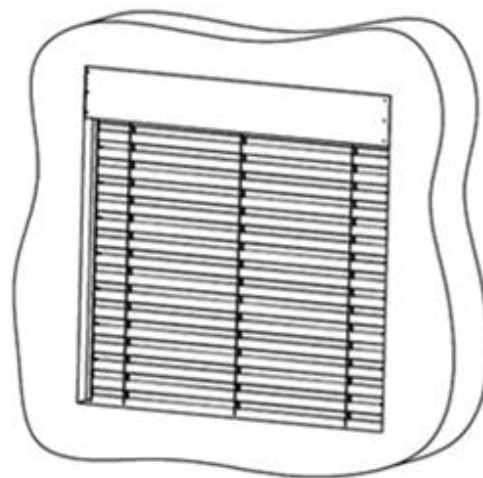

17.

BASIC TYPES OF ASSEMBLY

**Assembly of the blind into the reveal above the window (ceiling / wall)**

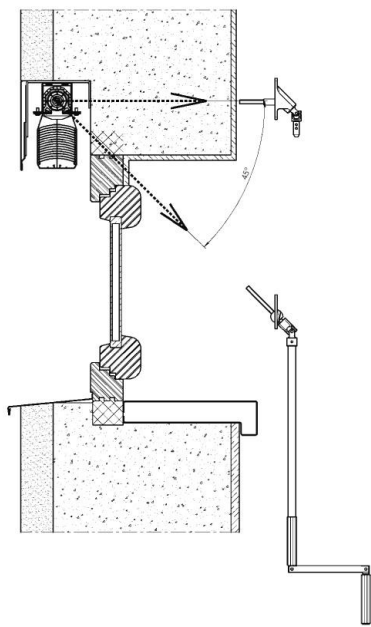

**Assembly of the blind into the reveal on the window frame (ceiling / wall)**

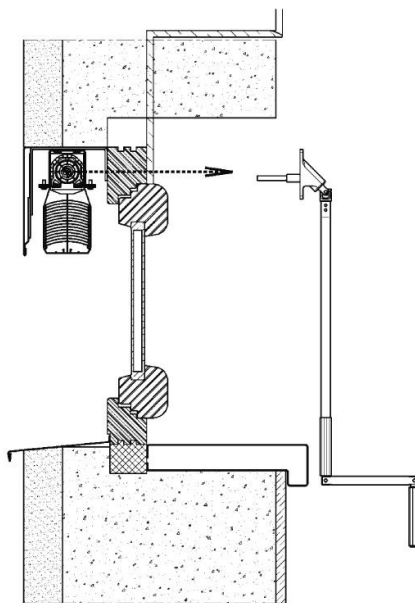

**Assembly of the blind into the reveal on the expansion frame (ceiling / wall)**

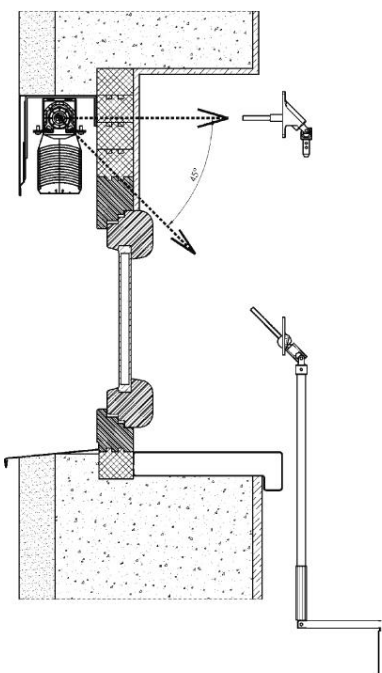

## ATTACHEMENT 1:

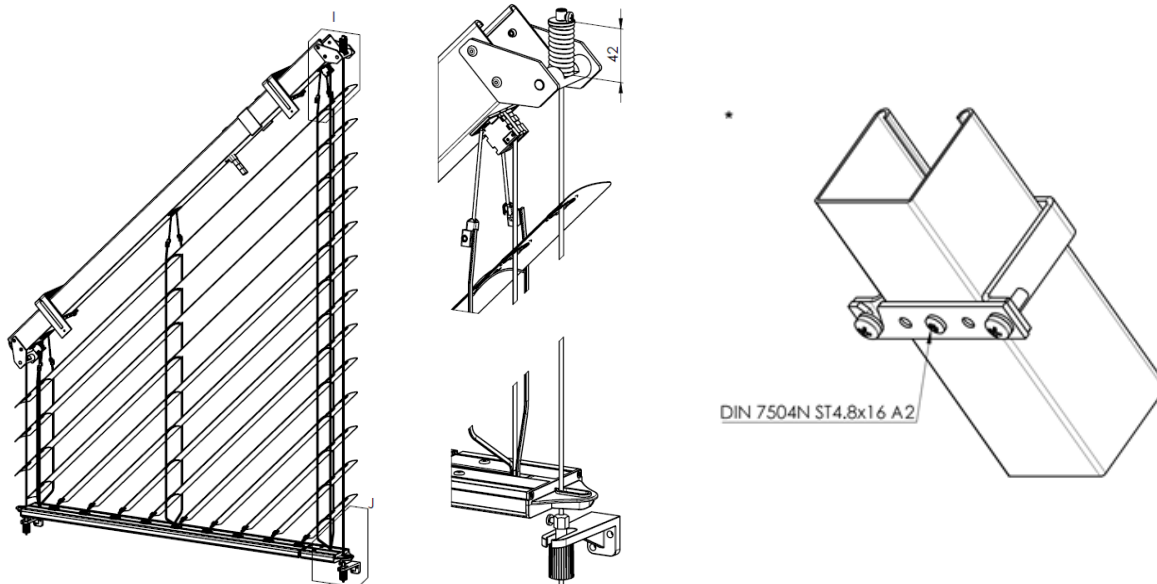
**Sloped blind – wire tensioning**

Using sloped blinds, it is necessary to achieve correct wire tension to avoid its big undesirable sag while retracting the blind.

Shorter side does not need non-standard tensioning – this is made by common tensioning mechanism. Wire tension strength is approx. 100 N (10Kg).

On the other hand, the longer side is equipped with special spring mechanism in upper part. In the lower part you will find standard wire tensioner without spring and with screw with full thread. With this you will achieve requested strength approx. 300 N (30Kg).

The correct tension can be measured on upper spring where its length including pressed ring shall be around 42mm (see picture).

Following the above steps, you will achieve correct tension for smooth run of sloped blinds.

**\*Prevention of unintended movement of the top profile**

Due to the interaction of factors such as manufacturing tolerances of the clamps and the top profile, coating, and the angle of inclination, unintended movement of the top profile in the holders may occur. To prevent this movement, we recommend fastening a self-drilling screw ST4.8x16 A2 DIN 7504N (6-018279-0000) through the clamp into the profile.

**ATTENTION!**

In case of sloped blind with telescopic bottom rail in it is necessary to regularly check the rail and avoid intrusion of undesirable elements (snow, ice, leaves, etc.) into the groove and mechanism of this telescopic bottom rail.

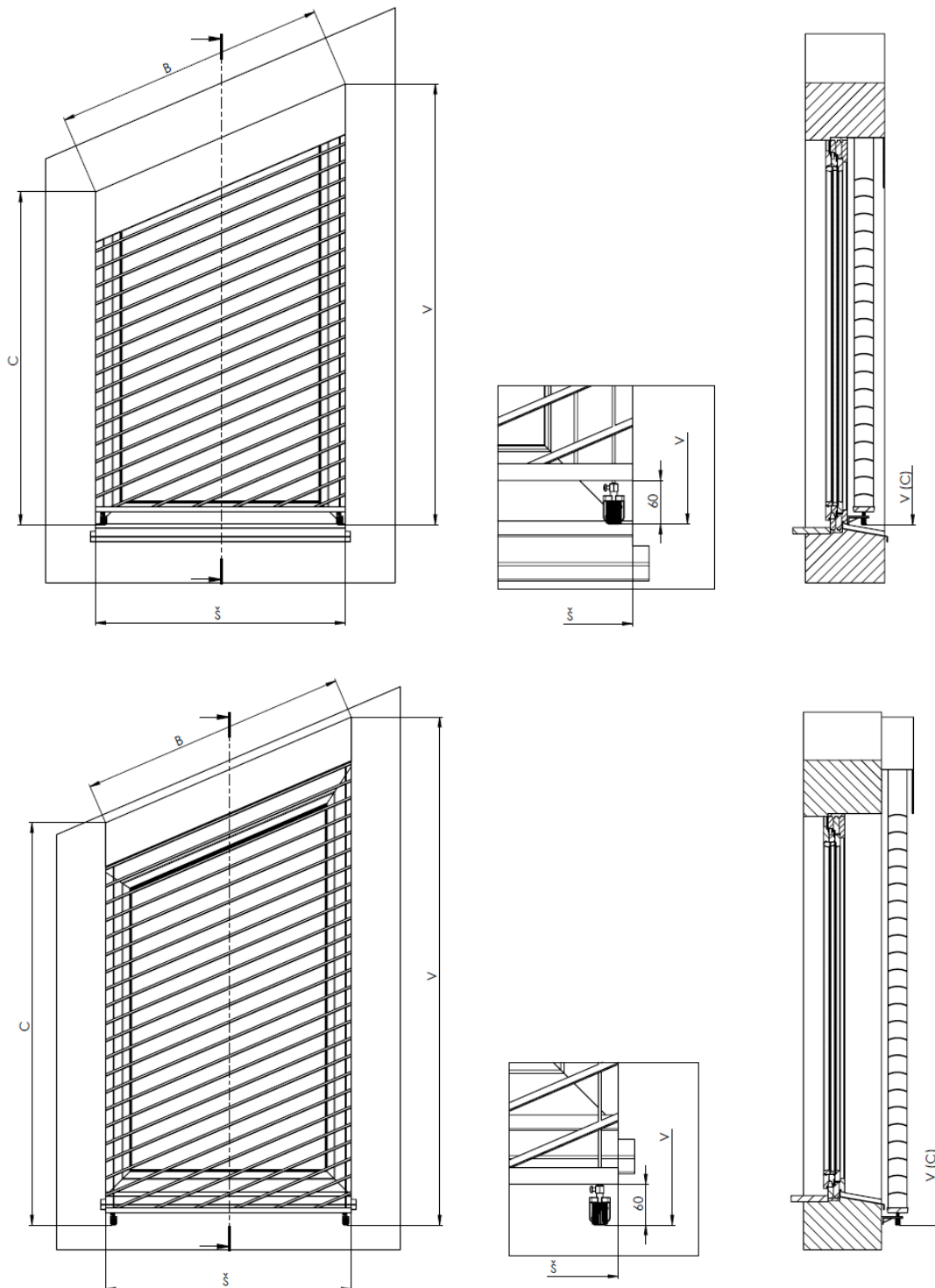

## MEASURING INSIDE THE SURROUND

- The figure presents a schematic view of the blind location.
- The blind is to be measured from the interior.
- A window surround is an architectural element, a lining of the wall apertures (for doors or windows), protruding above their surface, sometimes very significantly.
- When ordering, specify whether the measurements are dimensions of the clear opening, or of the finished product including any changes to the lower cord strainer!

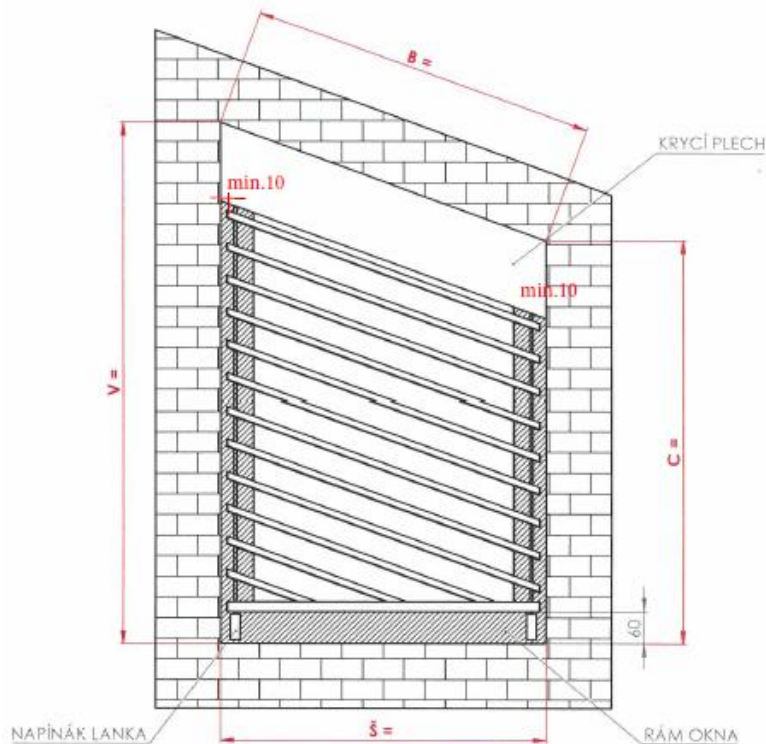

B = width of the surround in the inclined part

C = lower height of the surround

Š = horizontal width of the surround

V = upper height of the surround

KRYCÍ PLECH – COVER SHEET / NAPÍNÁK LANKA – CORD STRAINER / RÁM OKNA – WINDOW FRAME

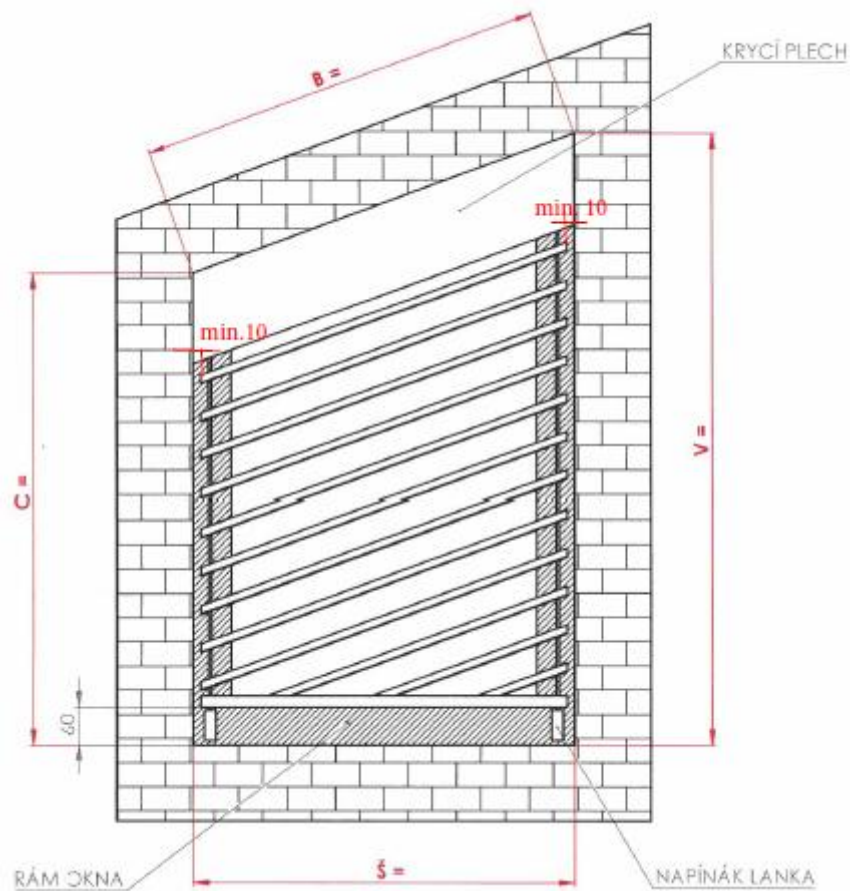

B = width of the surround in the inclined part

C = lower height of the surround

Š = horizontal width of the surround

V = upper height of the surround

KRYCÍ PLECH – COVER SHEET / NAPÍNÁK LANKA – CORD STRAINER / RÁM OKNA – WINDOW FRAME

## MEASURING OUTSIDE THE SURROUND

- The figure presents a schematic view of the blind location.
- The blind is to be measured from the interior.

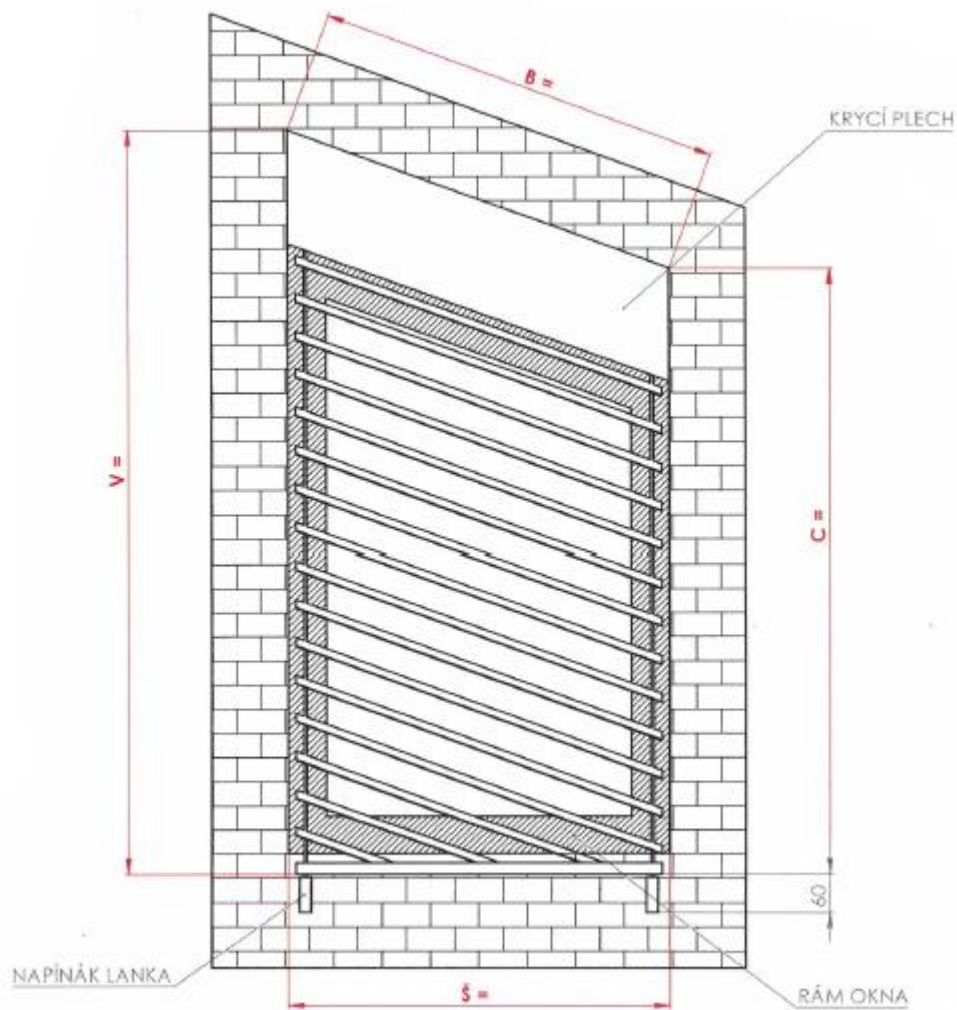

B = width of the surround in the inclined part

C = lower blind height without the cord strainer

Š = horizontal width of the surround

V = upper blind height without the cord strainer

KRYCÍ PLECH – COVER SHEET / NAPÍNÁK LANKA – CORD STRAINER / RÁM OKNA – WINDOW FRAME

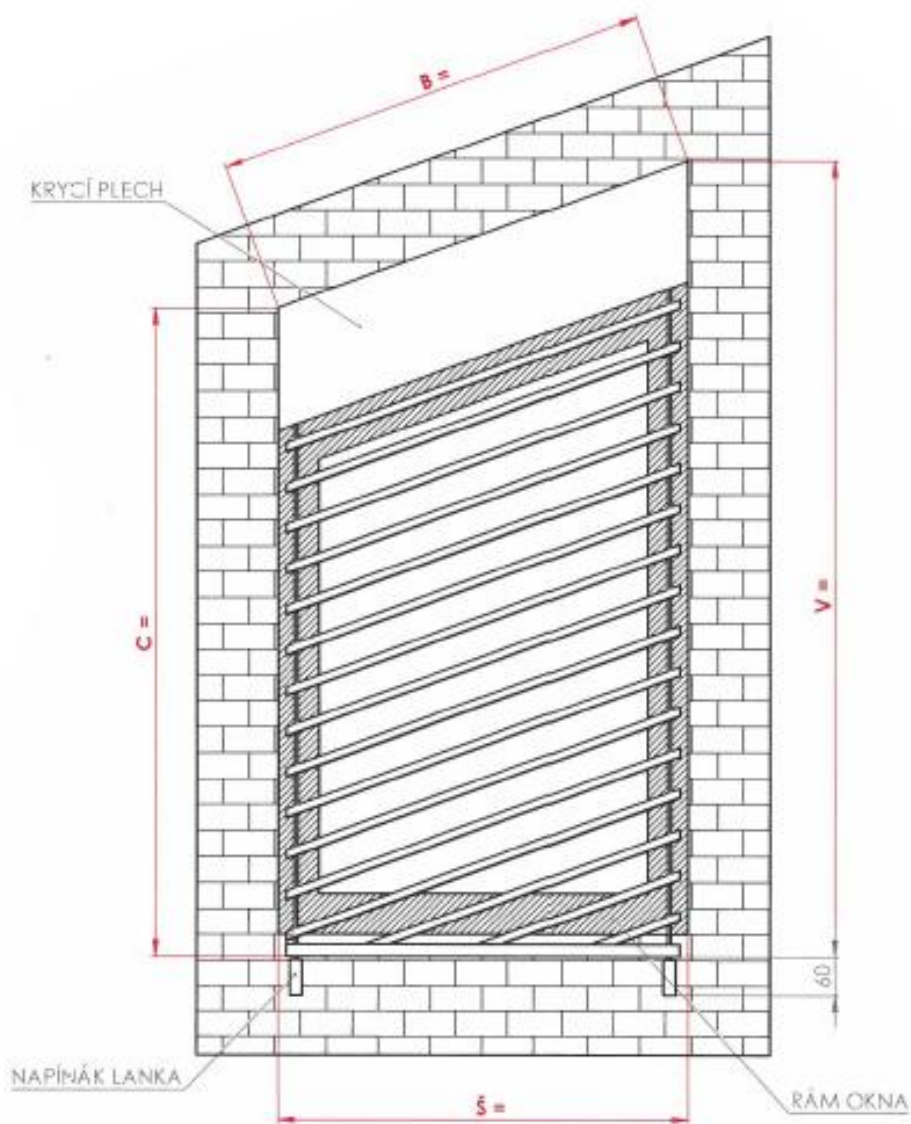

B = width of the surround in the inclined part

C = lower blind height without the cord strainer

Š = horizontal width of the surround

V = upper blind height without the cord strainer

KRYCÍ PLECH – COVER SHEET / NAPÍNÁK LANKA – CORD STRAINER / RÁM OKNA – WINDOW FRAME

## MEASURING INSIDE THE SURROUND

- The figure presents a schematic view of the blind location.
- The blind is to be measured from the interior.

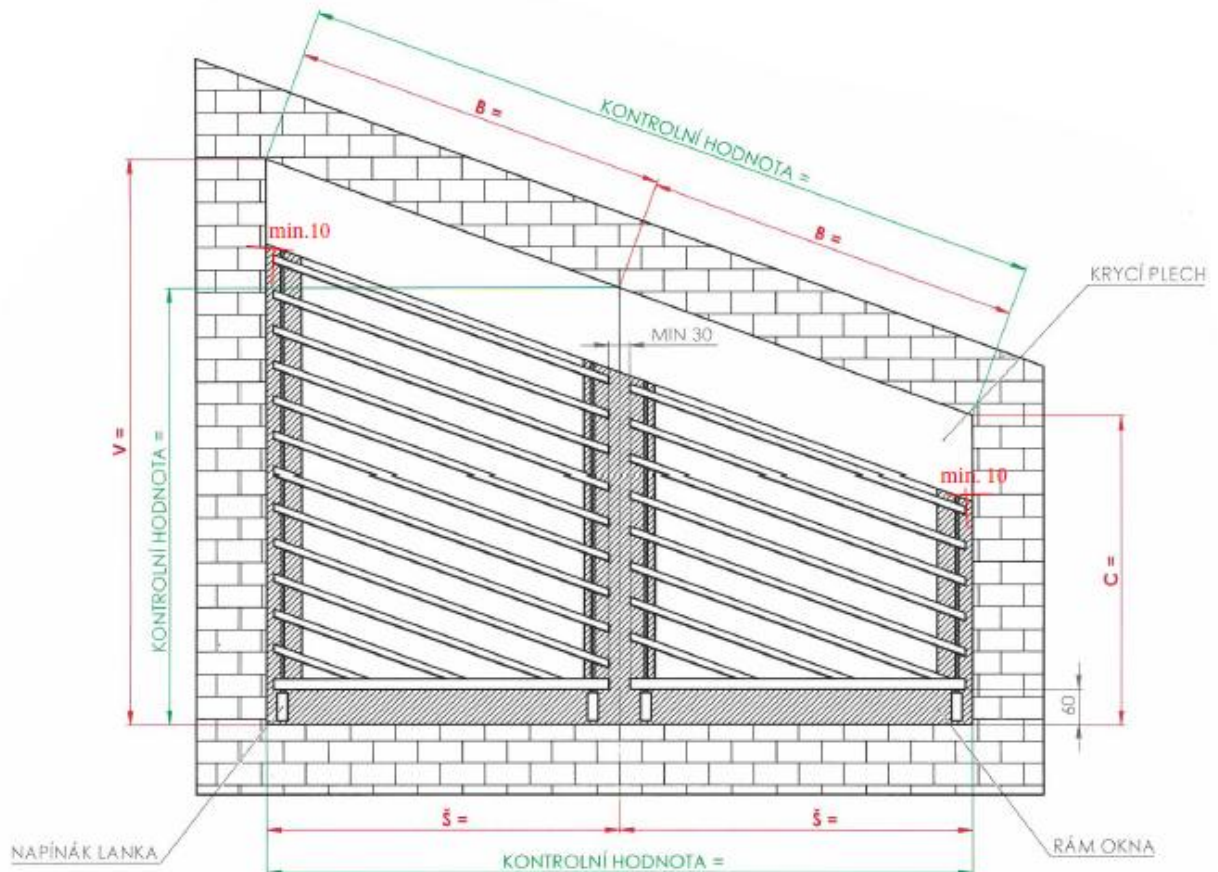

B = width of the required division in the inclined part

C = lower height of the surround

Š = width of the required division

V = upper height of the surround

Check value B = total width of the surround in the inclined part

Check value Š = total horizontal width of the surround

Check value V = height of the required division

KRYCÍ PLECH – COVER SHEET / NAPÍNÁK LANKA – CORD STRAINER / RÁM OKNA – WINDOW FRAME / KONTROLNÍ HODNOTA = CHECK VALUE

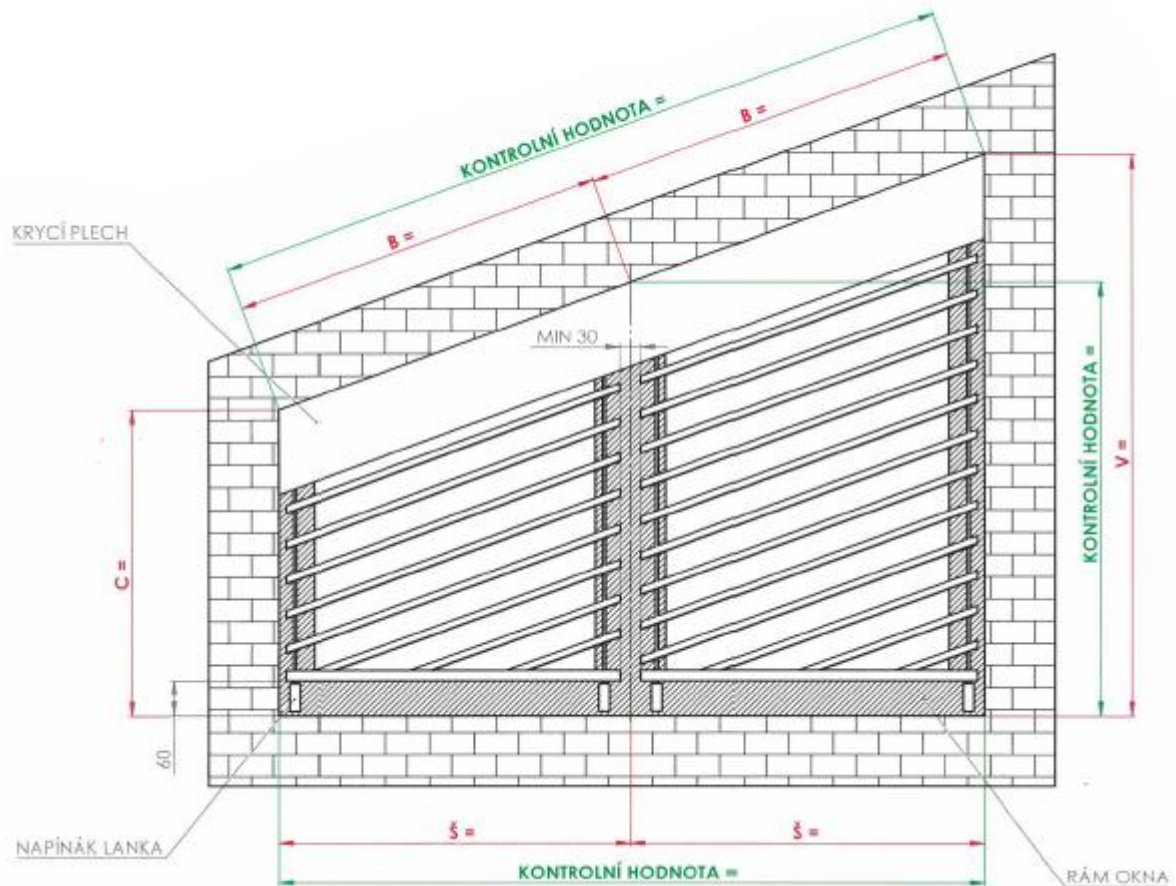

B = width of the required division in the inclined part

C = lower height of the surround

Š = width of the required division

V = upper height of the surround

Check value B = total width of the surround in the inclined part

Check value Š = total horizontal width of the surround

Check value V = height of the required division

KRYCÍ PLECH – COVER SHEET / NAPÍNÁK LANKA – CORD STRAINER / RÁM OKNA – WINDOW FRAME / KONTROLNÍ HODNOTA = CHECK VALUE

## MEASURING OUTSIDE THE SURROUND

- The figure presents a schematic view of the blind location.
- The blind is to be measured from the interior.

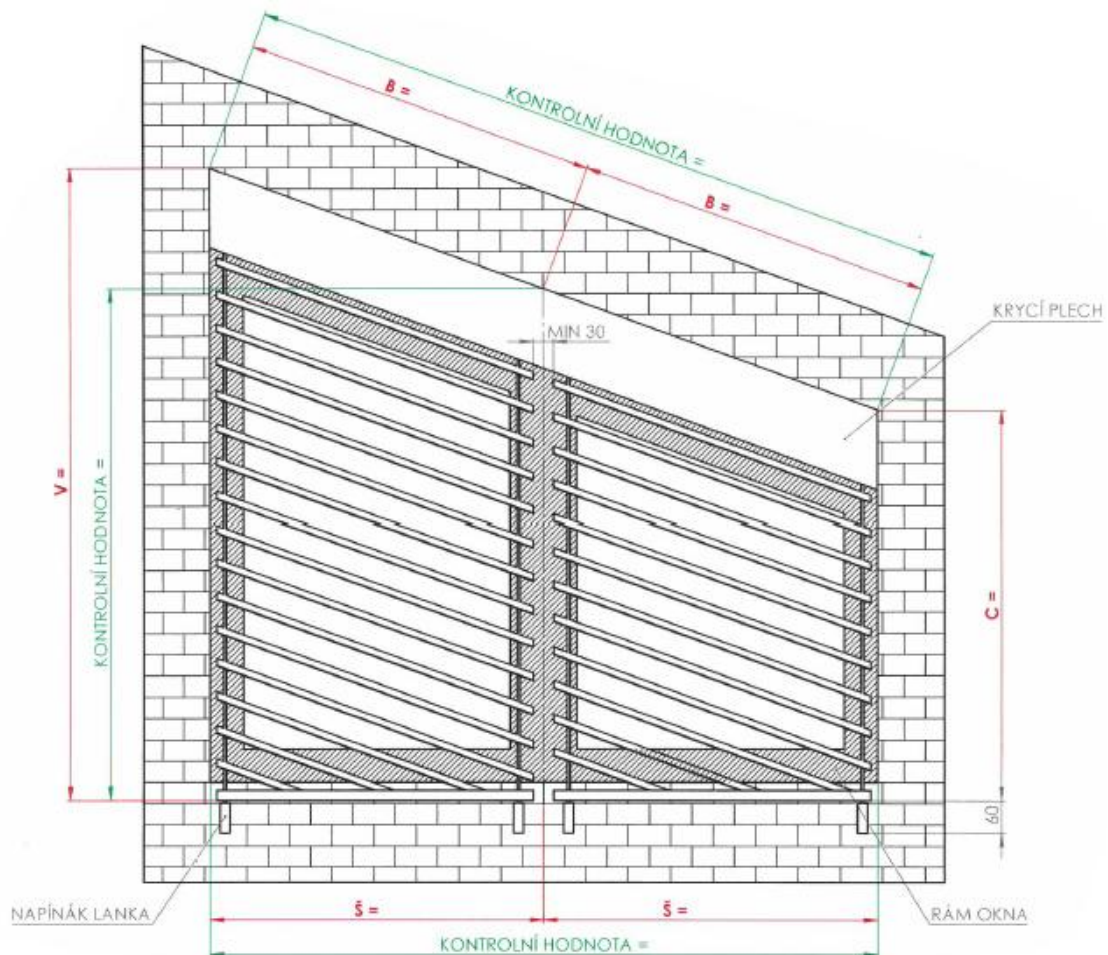

B = width of the required division in the inclined part

C = lower blind height without the cord strainer

Š = width of the required division

V = upper blind height without the cord strainer

Check value B = total width of the surround in the inclined part

Check value Š = total horizontal width of the surround

KRYCÍ PLECH – COVER SHEET / NAPÍNÁK LANKA – CORD STRAINER / RÁM OKNA – WINDOW FRAME / KONTROLNÍ HODNOTA = CHECK VALUE

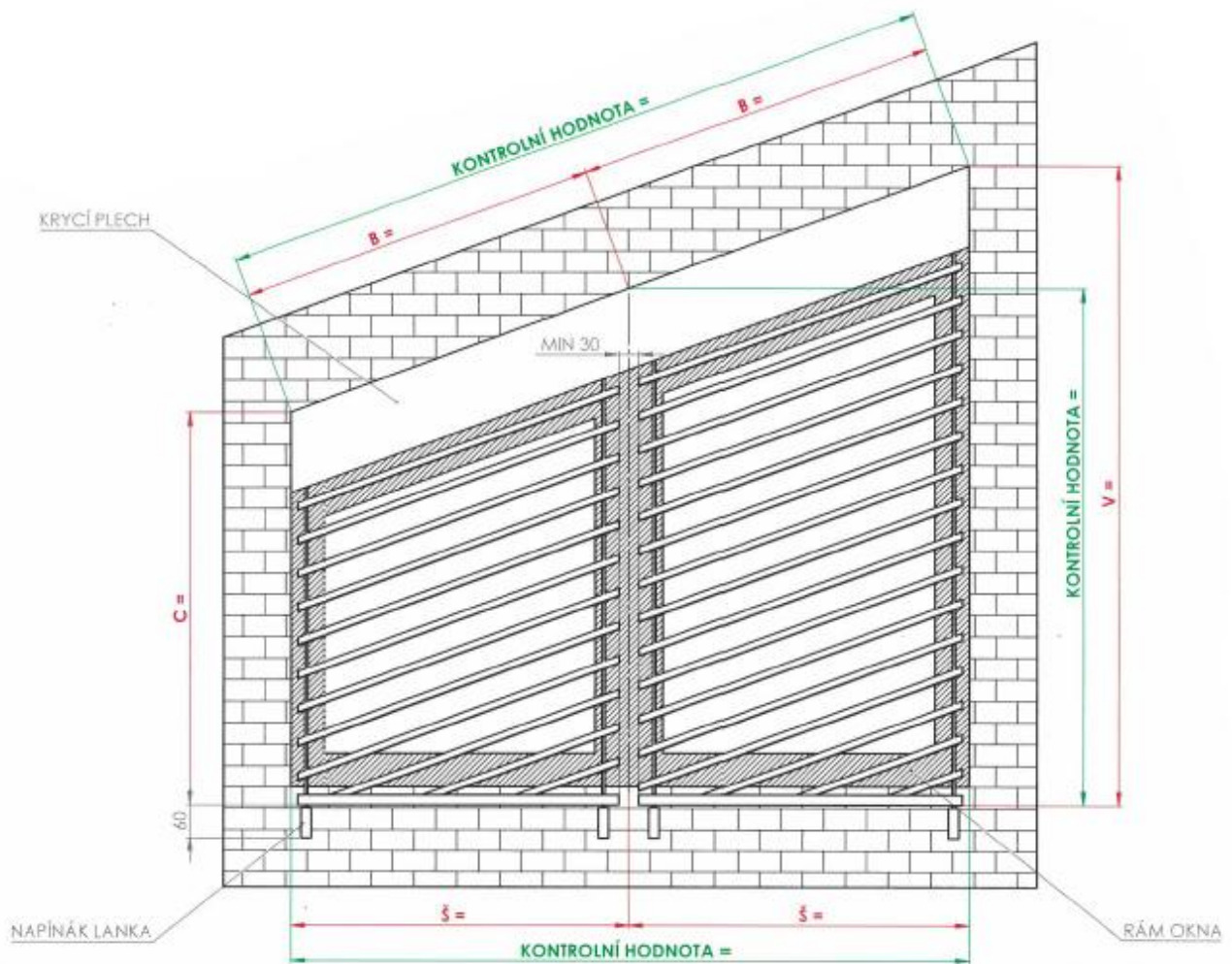

B = width of the required division in the inclined part

C = lower blind height without the cord strainer

Š = width of the required division

V = upper blind height without the cord strainer

Check value B = total width of the surround in the inclined part

Check value Š = total horizontal width of the surround

KRYCÍ PLECH – COVER SHEET / NAPÍNÁK LANKA – CORD STRAINER / RÁM OKNA – WINDOW FRAME / KONTROLNÍ HODNOTA = CHECK VALUE

## MEASURING INSIDE THE SURROUND

- The figure presents a schematic view of the blind location.
- The blind is to be measured from the interior.

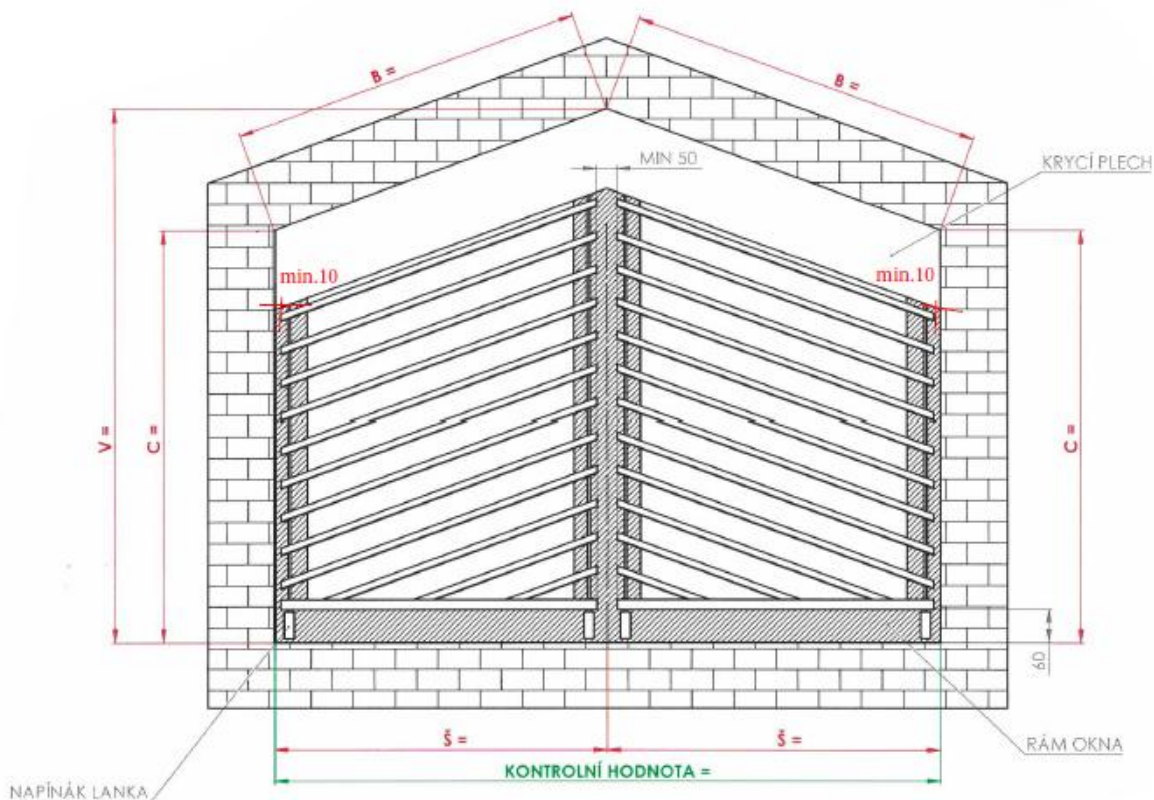

B = width of the surround in the inclined part

C = lower height of the surround

Š = width of the required division

V = upper height of the surround – crest

Check value Š = total horizontal width of the surround

KRYCÍ PLECH – COVER SHEET / NAPÍNÁK LANKA – CORD STRAINER / RÁM OKNA – WINDOW FRAME / KONTROLNÍ HODNOTA = CHECK VALUE

## MEASURING OUTSIDE THE SURROUND

- The figure presents a schematic view of the blind location.
- The blind is to be measured from the interior.

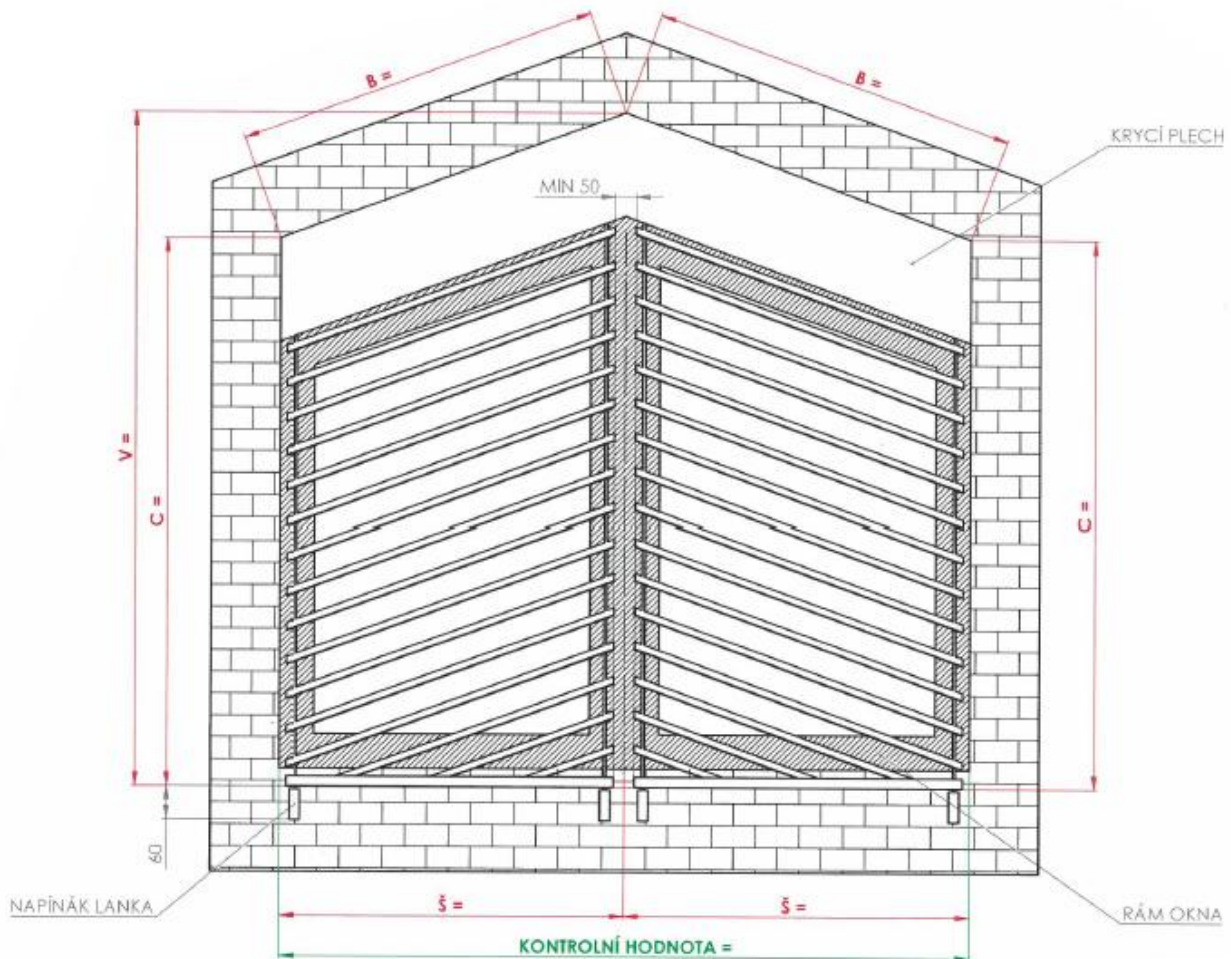

B = width of the surround in the inclined part

C = lower blind height without the cord strainer

Š = width of the required division

V = upper blind height without the cord strainer – crest

Check value Š = total horizontal width of the surround

KRYCÍ PLECH – COVER SHEET / NAPÍNÁK LANKA – CORD STRAINER / RÁM OKNA – WINDOW FRAME / KONTROLNÍ HODNOTA = CHECK VALUE